



Pressed bends with gasket BL



Rounded, reinforced
"SAFE" edges



Double gasket,
tightness class D



Automatic linear
welding



Top quality galvanised
steel 275 g/m²

Description

Pressed bends with gasket - "BL" **SAFE**, are made from top quality galvanised steel (275 g/m²). Pressing process as well as linear welding are fully automatic. With every edge "SAFE" type - reinforced with curved rims, provide additional bend rigidity and safe mounting. Double gasket EPDM clamped automatically ensure no risk of slipping during mounting. Product with **tightness class D**.

Technical drawing

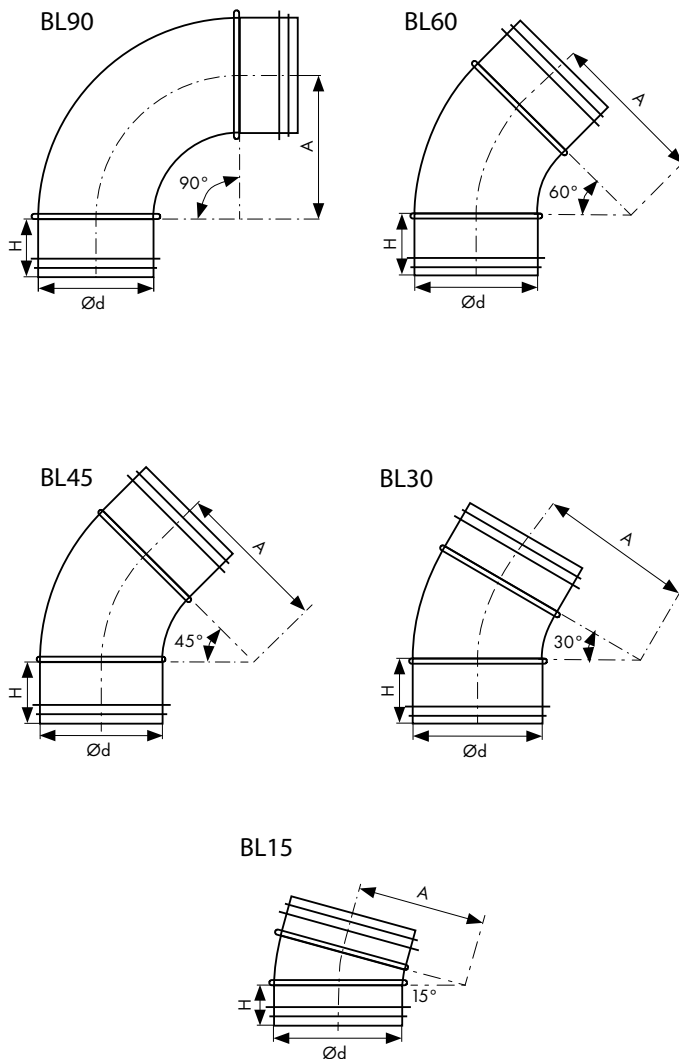

Dimensions BL90 [mm], Angle 90°

Ød nom.	A	H	kg	pcs/box	box type
80	100	35	0,27	85	P4
100	100	35	0,35	110	P2
125	125	35	0,52	60	P2
150	150	35	0,71	75	P1
160	160	35	0,83	60	P1
200	200	35	1,27	33	P1

Dimensions BL60 [mm], Angle 60°

Ød nom.	A	H	kg	pcs/box	box type
80	100	35	0,3	85	P6
100	100	35	0,4	40	P6
125	125	35	0,5	22	P6
150	150	35	0,9	15	P6
160	160	35	1,0	20	P4
200	200	35	1,5	12	P4

Dimensions BL45 [mm], Angle 45°

Ød nom.	A	H	kg	pcs/box	pallet packaging
80	100	35	0,19	90	P6
100	100	35	0,24	90	P4
125	125	35	0,34	100	P2
150	150	35	0,44	60	P2
160	160	35	0,52	110	P1
200	200	35	0,77	60	P1

Dimensions BL30 [mm], Angle 30°

Ød nom.	A	H	kg	pcs/box	box type
80	100	35	0,2	50	P12
100	100	35	0,3	75	P6
125	125	35	0,3	40	P6
150	150	35	0,4	25	P6
160	160	35	0,5	20	P6
200	200	35	0,7	16	P4

Dimensions BL15 [mm], Angle 15°

Ød nom.	A	H	kg	pcs/box	box type
80	100	35	0,2	54	P12
100	100	35	0,3	48	P12
125	125	35	0,3	27	P12
150	150	35	0,4	16	P12
160	160	35	0,5	16	P12
200	200	35	0,6	18	P6

 Packaging method on page 38