



ALPICAIR



Owner's Manual

Original Instructions

Commercial Air Conditioners

DC Inverter Multi VRF System

Models:

AOU-226VRDC3B

AOU-281VRDC3B

AOU-336VRDC3B

Thank you for choosing commercial air conditioners. Please read this Owner's Manual carefully before operation and retain it for future reference.



Preface

ALPICAIR DC Inverter Multi VRF System, with the most advanced technologies in the world, uses eco-friendly refrigerant R410A as its cooling medium. For correct installation and operation, please read this manual carefully. Before reading the manual, please note that:

- (1) Multi VRF system conforms to design standard: EN 14511-2011.
- (2) To ensure safety when operating this system, please strictly follow the instructions in this manual.
- (3) The total capacity of running indoor units must not exceed that of the outdoor units. Otherwise, the cooling (heating) effect of each IDU would be poor.
- (4) Make sure that this manual is kept by direct operators and maintainers.
- (5) In case of malfunction, please examine the following items and contact our authorized service centers as soon as possible.
 - 1) Nameplate (model, cooling capacity, product code, ex-factory date)
 - 2) Malfunction status (detail description of conditions before and after malfunction occurs)
- (6) All units have been strictly tested and proved to be qualified before ex-factory. To avoid damage or operation failure which may be caused by improper disassembly, please do not disassemble units by yourself. If disassembly is needed, please contact our authorized service centers.
- (7) All graphics and information in this manual are only for reference. Manufacturer reserves the right for changes in terms of sales or production at any time and without prior notice.
- (8) Under the standby status, the unit will consume a little power for ensuring reliability of complete unit, maintaining normal communication and preheating refrigerant. When the unit won't be used for a long time, cut off the power of the complete unit. However, please preheat it when operating the unit next time.















	Correct Disposal of this product
	This marking indicates that this product should not be disposed with other household wastes throughout the EU. To prevent possible harm to the environment or human health from uncontrolled waste disposal, recycle it responsibly to promote the sustainable reuse of material resources. To return your used device, please use the return and collection systems or contact the retailer where the product was purchased. They can take this product for environmental safe recycling.





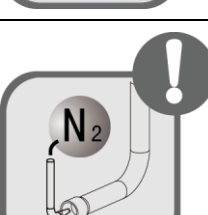



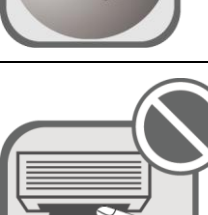
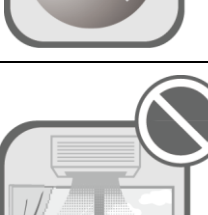

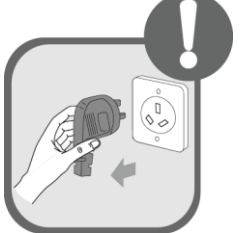

R410A(R32/125:50/50):2087.5

Contents

1 Safety Precautions.....	1
2 Product Introduction.....	3
2.1 Names of Main Parts	3
2.2 Combinations of Indoor and Outdoor Units	4
2.3 Operating Range.....	4
3 Preparation before Installation	4
3.1 Standard Parts	4
3.2 Installation Site.....	5
3.3 Piping Work Requirements	6
4 Installation Instruction	7
4.1 Dimension of Outdoor Unit and Mounting Hole	7
4.2 Connection Pipe.....	8
4.3 Installation of Connection Pipe	13
4.4 Vacuum Pumping, Refrigerant Adding.....	19
4.5 Electric Wiring	20
5 Check Items after Installation and Test Operation	24
5.1 Check Items after Installation	24
5.2 Test operation and debugging	25
6 Common Malfunctions and Troubleshooting.....	30
7 Error Indication	31
8 Function Setting of Outdoor Unit.....	34
8.1 ODU Quiet Function.....	34
8.2 Cool & Heat Function.....	35
8.3 Forced Defrosting	36
8.4 Restore Factory Defaults	37
8.5 Static Pressure Function	37
9 Maintenance and Care	37
9.1 Outdoor Heat Exchanger	37
9.2 Drain Pipe	37
9.3 Notice before Seasonal Use	38
9.4 Maintenance after Seasonal Use.....	38
9.5 Parts Replacement	38
10 After-sales Service	38

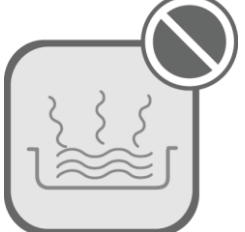
1 Safety Precautions

 Forbidden item! Improper operation might lead to personal injury or even death.			
 Item needs to be followed. Improper operation might lead to personal injury or property damage.			
	<p>Please install the unit according to instructions in this manual. Read this manual carefully before starting up or checking the machine.</p>		<p>Installation should be performed by distributor or qualified technicians. Do not install the product by yourself. Improper installation may result in water leakage, electric shock or fire hazard.</p>
	<p>Before installation, please check the power cord if it complies with the power supply requirement on the nameplate. Make sure the power supply is safe.</p>		<p>This air conditioner must be properly grounded through the receptacle to avoid electric shock. The ground wire shouldn't be connected with gas pipe, water pipe, lightning arrester or telephone line.</p>
	<p>When installing, specialized parts and accessories must be used. Otherwise, it may result in water leakage, electric shock or fire hazard.</p>		<p>R410A refrigerant can produce poisonous gas once it meets fire, so please ventilate the room immediately if refrigerant leaks out during installation.</p>
	<p>Diameter of power cord must be large enough. Damaged power cord or connecting wire must be replaced by specialized electric cable.</p>		<p>After the power cord is connected, please install the cover of electric box to avoid danger.</p>
	<p>Nitrogen must be charged according to technical requirements.</p>		<p>Short circuit is forbidden. Do not cancel the pressure switch, otherwise unit may be damaged.</p>
	<p>For units with wired controllers, do not connect power supply until the wired controller is well installed. Otherwise, the wired controller cannot be used.</p>		<p>When installation is finished, please check and make sure the drain pipe, pipeline and electric wire are all well connected so as to avoid water leakage, refrigerant leakage, electric shock and fire hazard.</p>
	<p>Do not extend fingers or objects into air outlet or return air grille.</p>		<p>If you use gas heater or petroleum heater in the same room, please open the door or window to maintain good air circulation, otherwise the room may be lack of oxygen.</p>

	<p>Never start or stop the air conditioner by inserting or removing the power cord.</p>		<p>Do not turn off the air conditioner until it runs for at least 5 minutes. Otherwise, oil return of the compressor will be affected.</p>
	<p>Children are not allowed to operate the air conditioner.</p>		<p>Do not operate the air conditioner with wet hands.</p>
	<p>Please turn off and unplug your air conditioner before cleaning. Otherwise, it may cause electric shock or personal injury.</p>		<p>Do not spray water on the air conditioner or it will cause malfunction or electric shock.</p>
	<p>Do not expose the air conditioner directly under damp or corrosive surroundings.</p>		<p>Connect power 8 hours before operation. Do not disconnect power when you want to stop the unit in a short period of time, e.g. in one night. (This is for protecting the compressor.)</p>
	<p>Volatile liquid like thinner or gasoline will damage the appearance of air conditioner. (Please use soft dry cloth and wet cloth with mild detergent to clean unit's outer case.)</p>		<p>Under cool mode, do not set the indoor temperature too low. Keep the difference between indoor temp and outdoor temp within 5°C.</p>
	<p>If abnormal condition occurs (e.g. unpleasant smell), please turn off the unit at once and disconnect power supply. Then contact ALPICAIR authorized service center. If the air conditioner continues to operate despite of abnormal condition, it may be damaged and cause electric shock or fire hazard.)</p>		<p>Do not repair the air conditioner by yourself. Improper repair will cause electric shock or fire hazard. Please contact ALPICAIR authorized service center and ask professional technicians to repair it.</p>
<p>This appliance can be used by children aged from 8 years and above and persons with reduced physical, sensory or mental capabilities or lack of experience and knowledge if they have been given supervision or instruction concerning use of the appliance in a safe way and understand the hazards involved. Children shall not play with the appliance. Cleaning and user maintenance shall not be made by children without supervision.</p>			
<p>ALPICAIR Electric will not assume responsibility for any personal injury or property loss caused by improper installation, improper debugging, unnecessary repair or not following the instructions of this manual.</p>			

2 Product Introduction

ALPICAIR Multi VRF System adopts inverter compressor technology. By changing the displacement of compressor, stepless capacity regulation within range of 10%~100% can be realized. Various product lineups are provided with capacity range from 22.4kW to 35kW, which can be widely used in residential, commercial and working area and especially applicable to places with big load change. ALPICAIR residential air conditioner is absolutely your best choice.

2.1 Names of Main Parts

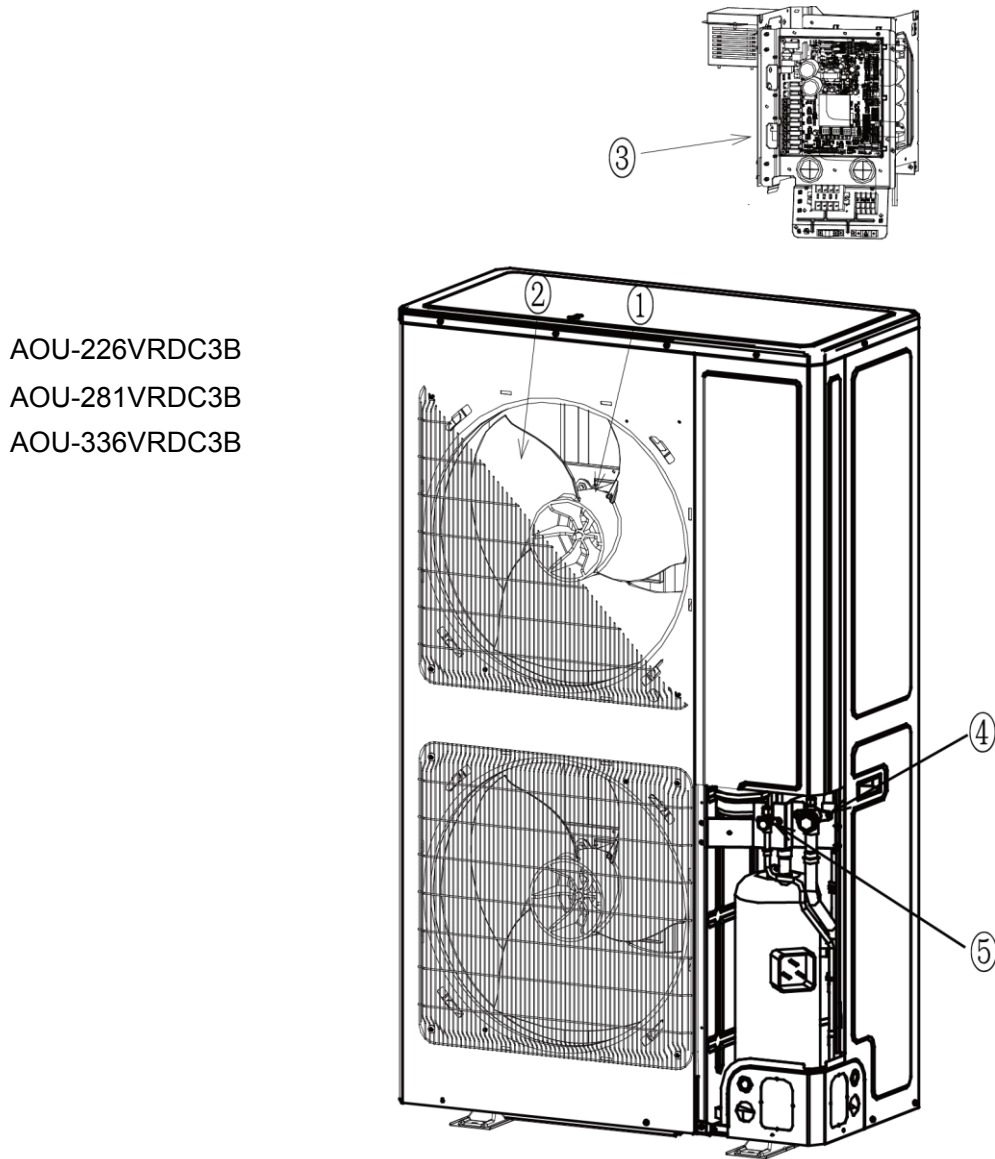

Fig.1

No.	①	②	③	④	⑤
Name	Motor	Fan blade	Electric box assembly	Gas pipe valve	Liquid pipe valve

2.2 Combinations of Indoor and Outdoor Units

- (1) See below the number of indoor units that can be connected to the outdoor unit.
- (2) The total capacity of indoor units should be within 50%~135% of that of the outdoor unit.

Model	Max sets of connectable IDUs
AOU-226VRDC3B	13
AOU-281VRDC3B	17
AOU-336VRDC3B	20

- (3) can be connected to various indoor units. When any one of the indoor units receives operating command, outdoor unit will start operation as per required capacity. When all indoor units stop, outdoor unit will be shut off.

2.3 Operating Range

Cooling	Outdoor temperature: -5°C~52°C
Heating	Outdoor temperature: -20°C~27°C

3 Preparation before Installation



Note: Graphics here are only for reference. Please refer to actual products. Unspecified dimensions are all in mm.





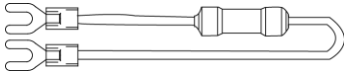
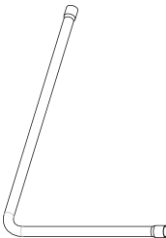

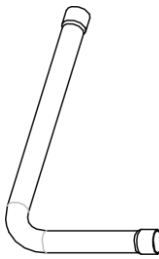
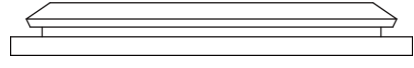
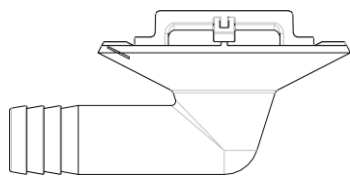
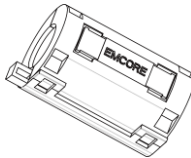

3.1 Standard Parts

Please use the supplied standard parts as required.

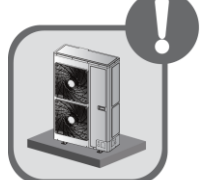
Parts for Outdoor Unit				
No.	Name	Appearance	Qty	Remark
1	User Manual		1	
2	Wiring (match with resistance)		1	Must be connected to the last IDU of communication connection
3	Liquid side connection pipe		1	This part is included in the following models: AOU-226VRDC3B

Parts for Outdoor Unit				
No.	Name	Appearance	Qty	Remark
4	Gas side connection pipe		1	This part is included in the following models: AOU-226VRDC3B
5	Drainage hole cap		3	
6	Drainage joint		1	
7	Magnetic ring		1	Please refer to section 4.5.2 for the detailed operation method.

3.2 Installation Site

 Forbidden item! Improper operation might lead to personal injury or even death.			
 Item needs to be followed. Improper operation might lead to personal injury or property damage.			
	Select a location which is strong enough to hold unit's weight so that unit can stand still and erect.		The installation position should withstand strong wind, typhoon and earthquake. The unit must be installed stably.
	Please keep the unit away from inflammable, explosive and corrosive gas or waste gas.		Make sure the location has space for heat exchange and maintenance so that unit can operate reliably with good ventilation.
	ODU and IDU should stay as close as possible to shorten the length of refrigerant pipe and reduce bend angles.		Select a location which is out of children's reach. Keep the unit away from children.

If the ODU is totally surrounded by walls, please refer to the following figures for space dimension:

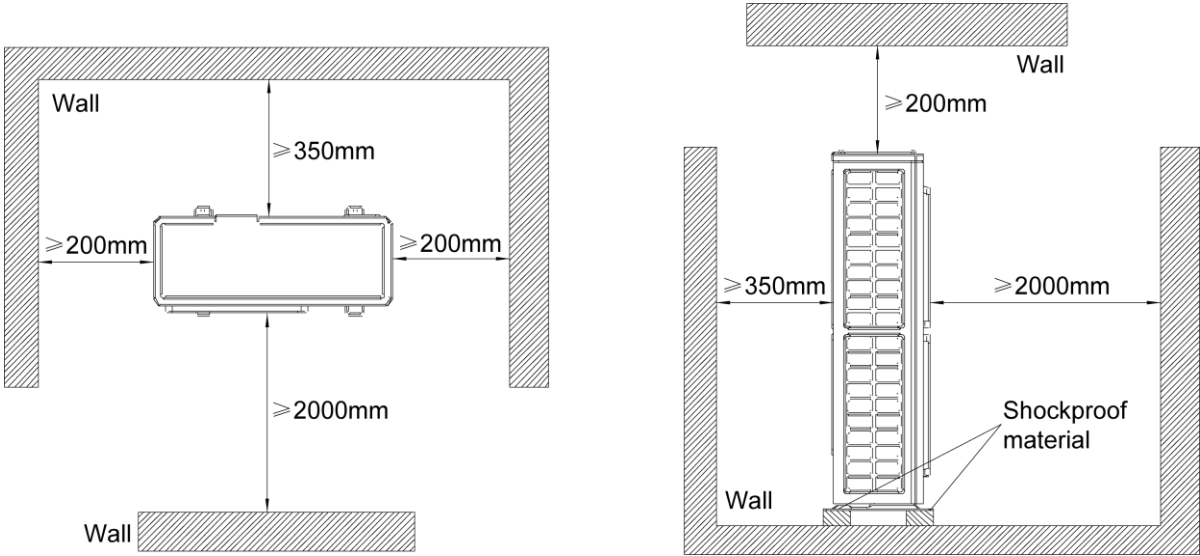

Fig.2

3.3 Piping Work Requirements

Refer to the table below for piping work requirements:

R410A Refrigerant System	
Outer diameter (mm/inch)	Wall thickness(mm)
Φ6.35(1/4)	≥0.8
Φ9.52(3/8)	≥0.8
Φ12.70(1/2)	≥0.8
Φ15.9(5/8)	≥1.0
Φ19.05(3/4)	≥1.0
Φ22.20(7/8)	≥1.2
Φ25.40(8/8)	≥1.2

4 Installation Instruction



Note: Graphics here are only for reference. Please refer to actual products. Unspecified dimensions are all in mm.

4.1 Dimension of Outdoor Unit and Mounting Hole

Unit Outline and Installation Dimension (mm)

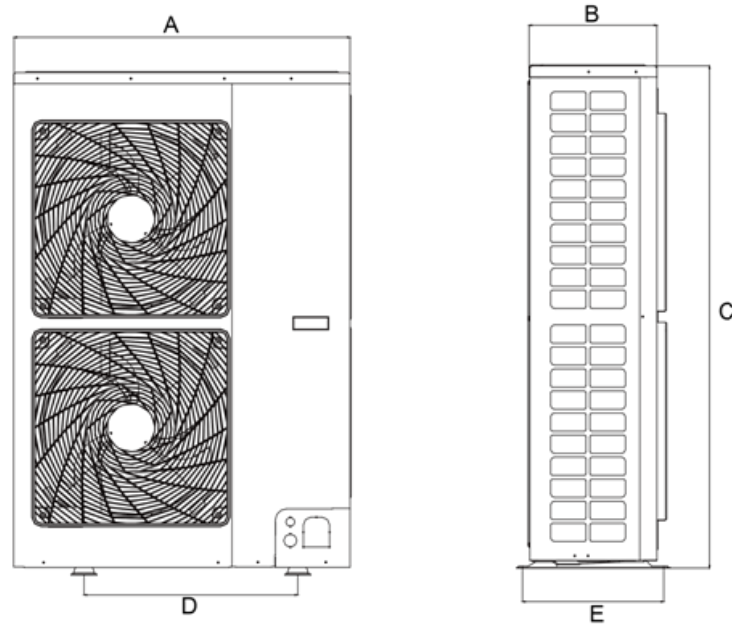

Fig.3

in mm

MODEL	A	B	C	D	E
AOU-226VRDC3B	940	320	1430	632	350
AOU-281VRDC3B	940	460	1615	610	486
AOU-336VRDC3B	940	460	1615	610	486

4.2 Connection Pipe

4.2.1 Schematic Diagram of Piping Connection

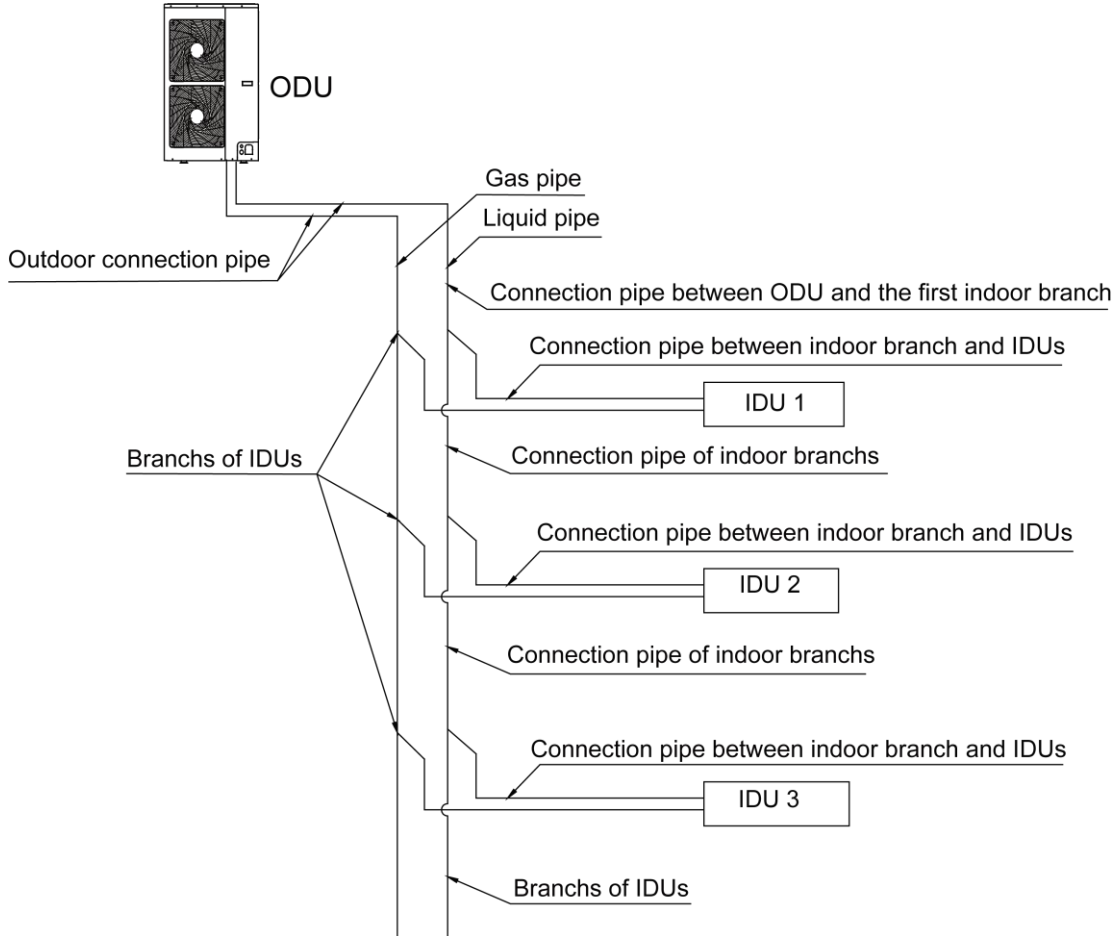

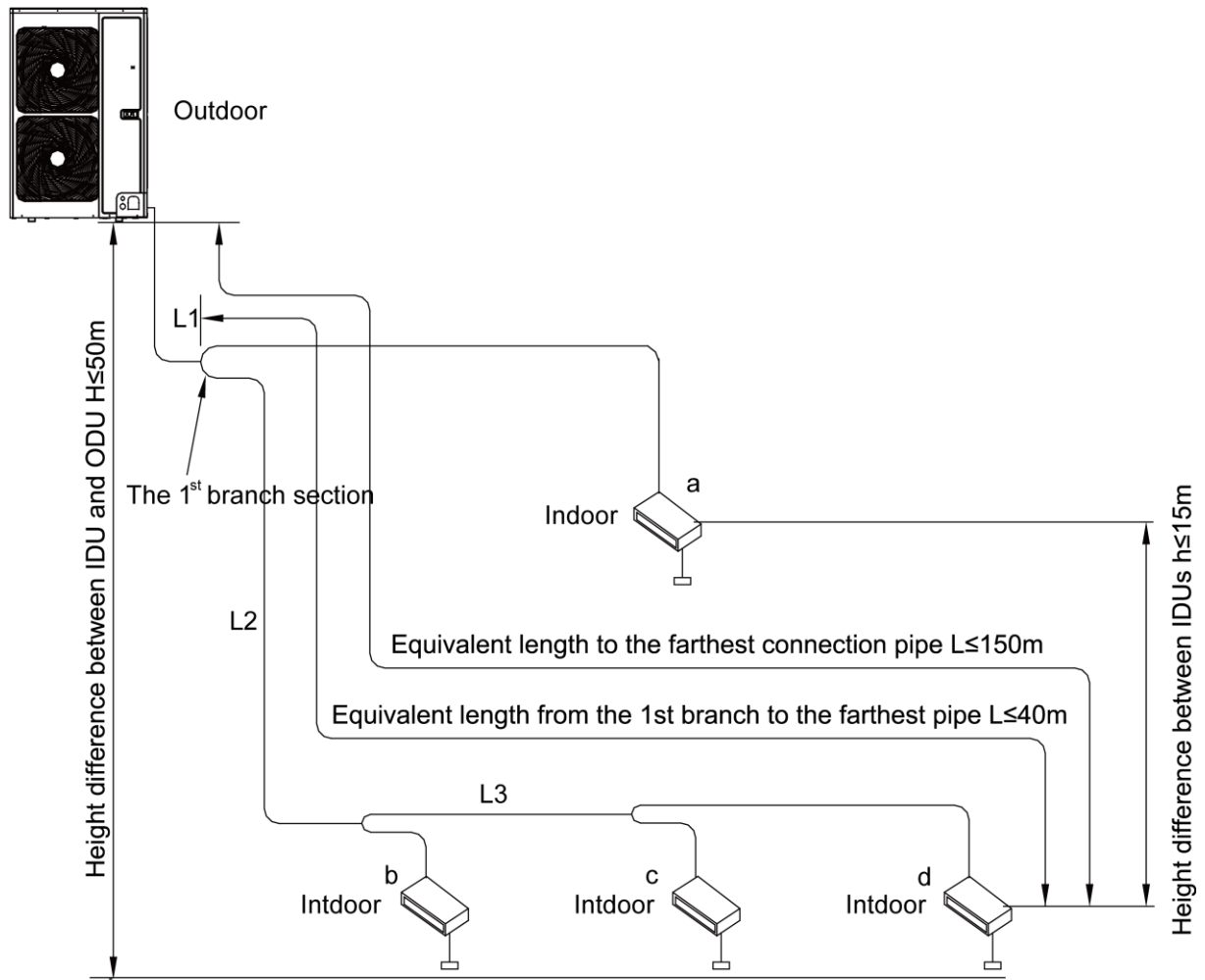

Fig.4

4.2.2 Allowable Length and Height Difference of Connection Pipe

Y type branch joint is adopted to connect indoor and outdoor units. Connecting method is shown in the figure below:

 Note : Equivalent length of one Y-type branch is 0.5m.



Each Y-type branch equals to 0.5m and each branch header equals to 1.0m.

Fig.5 Allowable Length and Height Difference of Connection Pipe

Piping parameters of AOU-226VRDC3B,AOU-281VRDC3B,AOU-336VRDC3B

		Allowable value	Fitting pipe
Total length (actual length) of fitting pipe		300m	$L1+L2+L3+a+b+c+d$
Length of farthest fitting pipe (m)	Actual length	120m	$L1+L2+L3+d$
	Equivalent length	150m	
From the 1 st branch to the farthest indoor pipe		40m	$L2+L3+d$
Height difference between ODU and IDU	ODU at upper side	50m	—
	ODU at lower side	40m	—
Height difference between IDUs		15m	—

4.2.3 Dimension of Pipe (Main Pipe) from ODU to the 1st Indoor Branch

Dimension of pipe from ODU to the 1st indoor branch will be determined by the dimension of outdoor connection pipe.

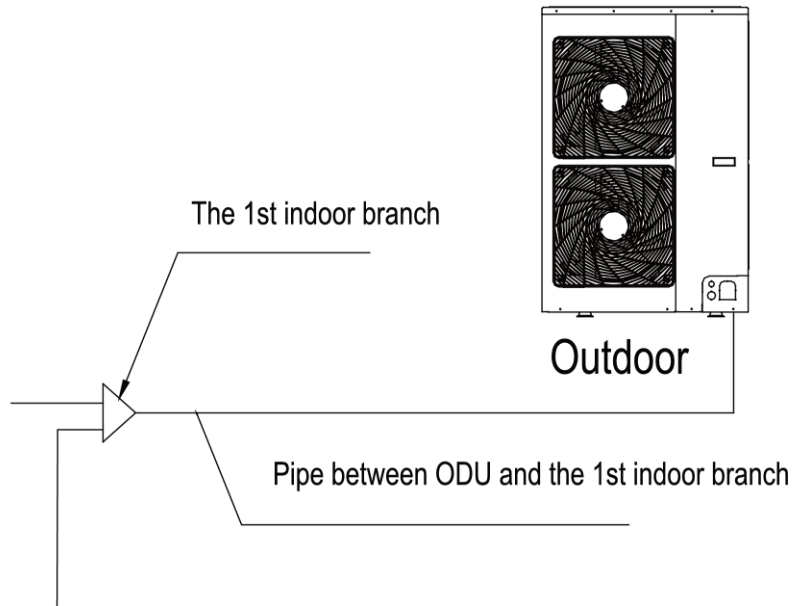

Fig.6

Dimension of outdoor connection pipe

Basic module	Pipe dimension		Connection method
	Gas pipe (mm)	Liquid pipe (mm)	
AOU-226VRDC3B	Φ19.05	Φ9.52	Welding connection
AOU-281VRDC3B	Φ22.20	Φ9.52	
AOU-336VRDC3B	Φ25.40	Φ12.70	

4.2.4 Selection of Indoor Branches

Select indoor branches according to the total capacity of downstream indoor units. If the capacity exceeds that of the outdoor unit, capacity of outdoor unit prevails.

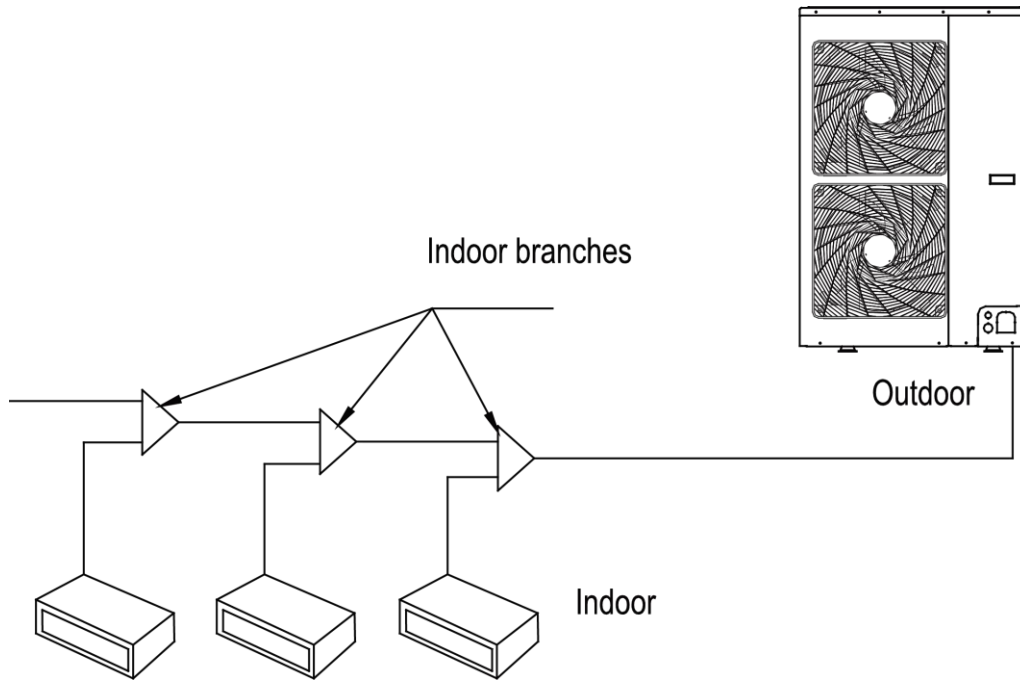

Fig.7

R410A Refrigerant system	Total capacity of downstream indoor units X (kW)	Model
Y type branch	$X < 20$	FQ01A
	$20 \leq X \leq 30$	FQ01B
	$30 < X \leq 70$	FQ02
	$70 < X \leq 135$	FQ03
	$135 < X$	FQ04

4.2.5 Dimension of Pipe between Indoor Branches

Select pipe between indoor branches according to the capacity of downstream indoor units; If the capacity exceeds that of the outdoor unit, capacity of outdoor unit prevails.

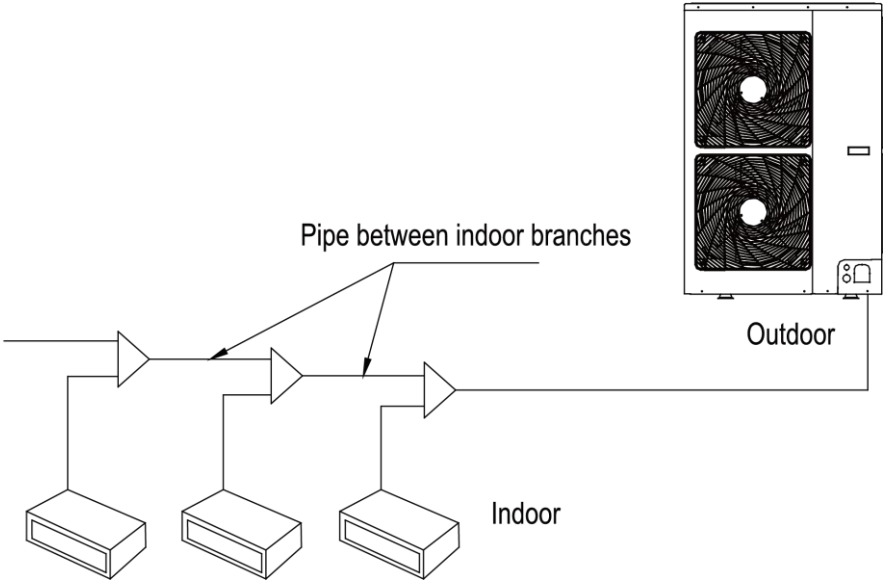

Fig.8

Total capacity of downstream indoor units C (kW)	Gas pipe (mm)	Liquid pipe (mm)
$C \leq 5.6$	$\Phi 12.7$	$\Phi 6.35$
$5.6 < C \leq 14.2$	$\Phi 15.9$	$\Phi 9.52$
$14.2 < C \leq 22.4$	$\Phi 19.05$	$\Phi 9.52$
$22.4 < C \leq 33.5$	$\Phi 25.40$	$\Phi 12.70$

4.2.6 Dimension of Pipe between Indoor Branch and IDU

Dimension of pipe between indoor branch and IDU should be consistent with the dimension of indoor pipe.

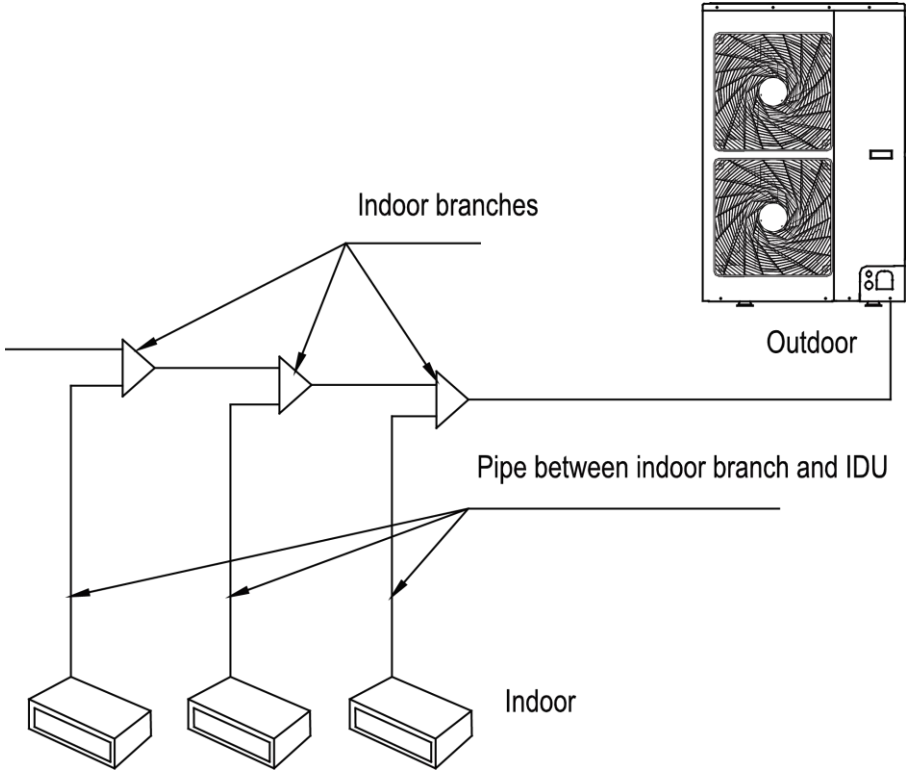

Fig. 9

Rated capacity of IDU C(kW)	Gas pipe (mm)	Liquid pipe (mm)
$C \leq 2.8$	$\Phi 9.52$	$\Phi 6.35$
$2.8 < C \leq 5.0$	$\Phi 12.7$	$\Phi 6.35$
$5.0 < C \leq 14.0$	$\Phi 15.9$	$\Phi 9.52$
$14.0 < C \leq 16.0$	$\Phi 19.05$	$\Phi 9.52$
$16.0 < C \leq 28.0$	$\Phi 22.2$	$\Phi 9.52$



Note: If the distance between IDU and its nearest branch is over 10m, then the liquid pipe of IDU (rated capacity ≤ 5.0 kW) shall be enlarged.

4.3 Installation of Connection Pipe

4.3.1 Precautions for the Installation of Connection Pipe

- (1) Conform to the following principles during pipe connection: Connection pipe should be as short as possible, so is the height difference between indoor and outdoor units. Keep the number of bends as little as possible. Radius of curvature should be as large as possible.
- (2) Weld the connection pipe between indoor and outdoor units. Please strictly follow the requirements for welding process. Rosin joint or pin hole is not allowed.
- (3) Radius of bending parts should be over 200mm. Note that pipes cannot be repeatedly bent or stretched; otherwise the material will get harder. Do not bend or stretch the pipe for more than 3 times at the same position.

4.3.2 Flaring Process

- (1) Use pipe cutter to cut the connection pipe in case it is unshaped.
- (2) Keep the pipe downward in case cutting scraps get into the pipe. Clear away the burrs after cutting.
- (3) Remove the flared nut connecting indoor connection pipe and outdoor unit. Then use flaring tool to fix the flared nut into the pipe (as shown in Fig.10).
- (4) Check if the flared part is flaring evenly and if there is any crack.

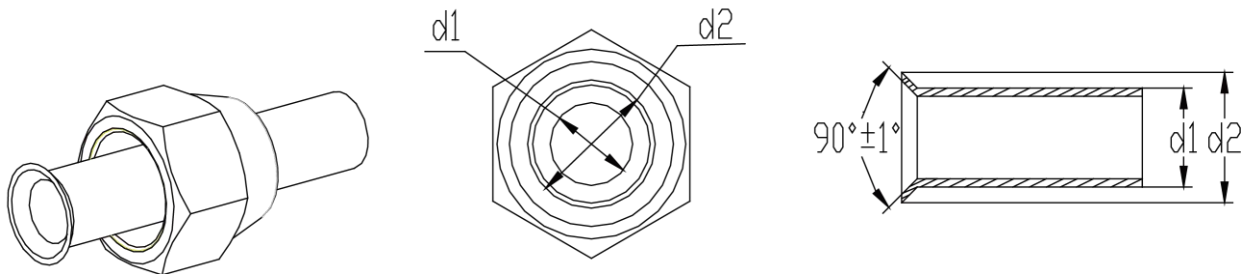

Fig. 10

4.3.3 Pipe Bending

- (1) Reshape the pipe by hand. Be careful not to damage the pipe.

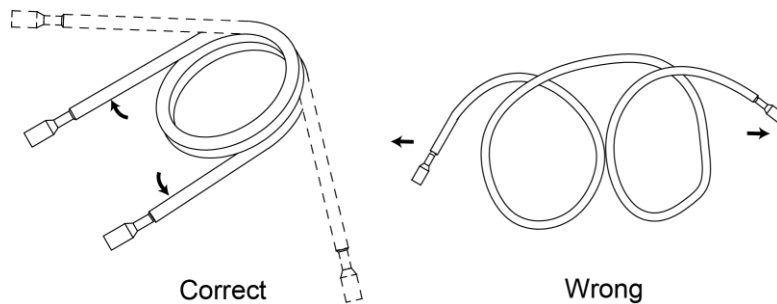

Fig. 11

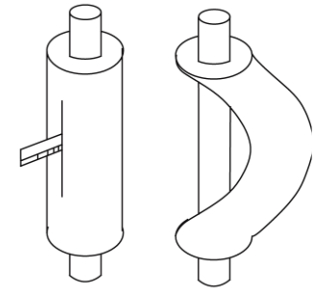

Fig. 12

- (2) Do not bend the pipe over 90°.
- (3) If pipe is repeatedly bent or stretched, it will get hard and difficult to bend and stretch again. Therefore, do not bend or stretch the bend for over 3 times.
- (4) In case that direct bending will open cracks to the pipe, first use sharp cutter to cut the insulating layer, as shown in Fig.12. Do not bend the pipe until it is exposed. When bending is done, wrap the pipe with insulating layer and then secure it with adhesive tape.

4.3.4 Indoor Pipe Connection

- (1) Remove pipe cover and pipe plug.
- (2) Direct the flared part of copper pipe to the center of screwed joint. Twist on the flared nut tightly by hand, as in Fig.13. (Make sure indoor pipe is correctly connected. Improper location of the center will prevent flared nut from being securely twisted. Thread of nut will get damaged if the flared nut is twisted forcibly.)
- (3) Use torque wrench to twist on the flared nut tightly until the wrench gives out a click sound. (Hold the handle of wrench and make it at right angle to the pipe. as in Fig.14)
- (4) Use sponge to wrap the un-insulated connection pipe and joint. Then tie the sponge tightly with plastic tape.
- (5) Connection pipe should be supported by a bearer rather than the unit.
- (6) The bending angle of piping should not be too small; otherwise the piping might have cracks. Please use a pipe bender to bend the pipe.
- (7) When connecting IDU with connection pipe, do not pull the big and small joints of IDU with force in case the capillary tube or other tubes have cracks and cause leakage.

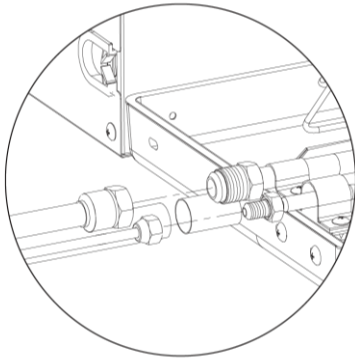

Fig. 13

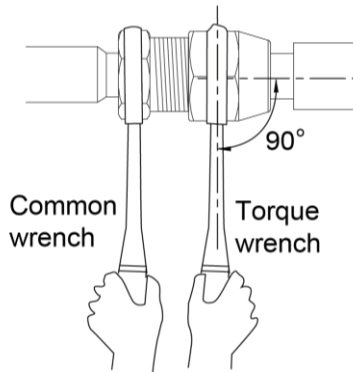

Fig. 14

Pipe dimension	Tightening torque
φ 6mm	15 ~ 30 (N • m)
φ 9. 52mm	35 ~ 40 (N • m)
φ 12mm	45 ~ 50 (N • m)
φ 16mm	60 ~ 65 (N • m)

4.3.5 Outdoor Pipe Connection

During engineering installation, the connection pipe inside the unit must be wrapped by insulation sleeve.

- (1) Pipe connection for AOU-226VRDC3B:As shown in Fig.15 and Fig.16, open the outermost soundproof cotton and place a fire barrier between compressor and straight pipe. Use a soldering gun to unsolder straight pipe 1 and straight pipe 2. Install connection pipe 1 and connection pipe 2 to the corresponding position and then seal the apertures with welding rod. First weld the liquid side connection pipe and then weld the gas side connection pipe. During welding, it's necessary to use wet gauze to wrap up the two cut-off valves. Make sure the flame won't burn the soundproof cotton or other components.

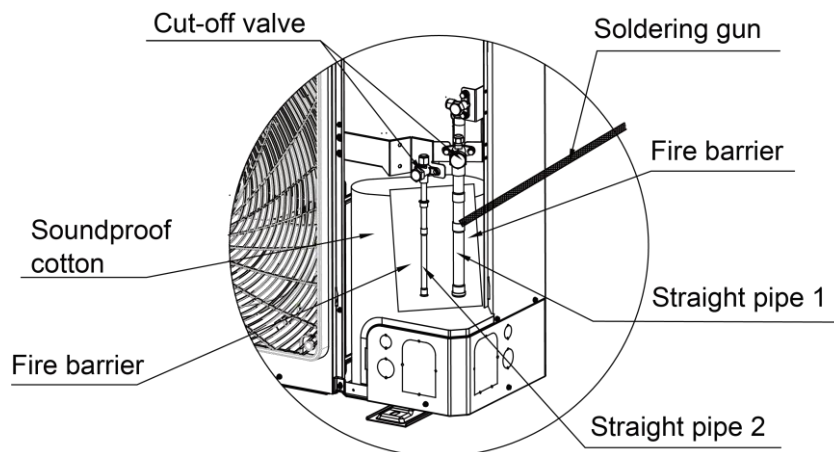

Fig. 15

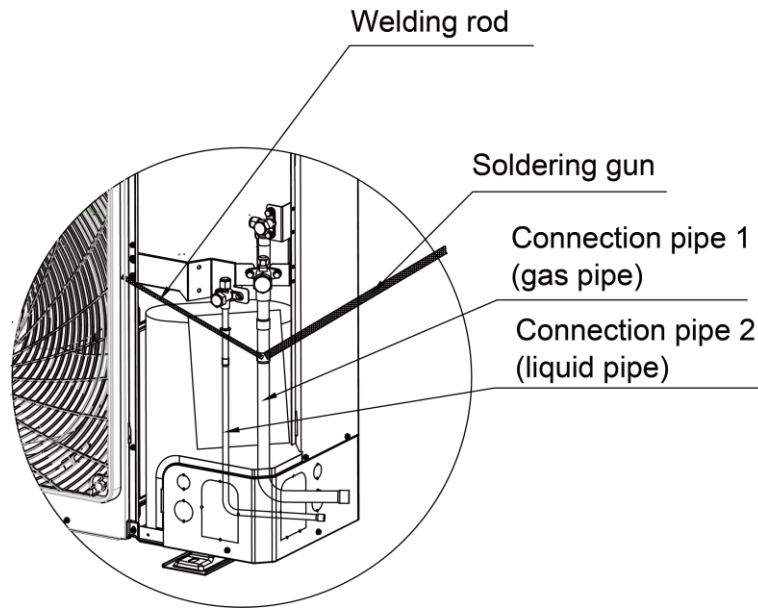

Fig. 16

(2) Pipe connection for

AOU-281VRDC3B,AOU-336VRDC3B:

- 1) If connection pipe is connected at the front, no special treatment is needed. You can weld the pipeline directly to connection pipe 1 and connection pipe 2.
- 2) If connection pipe is connected at the side as shown in Fig.17 and Fig.18, open the front side plate, rear side plate and connection board. Then open the soundproof cotton. Use a soldering gun to unsolder connection pipe 1 and connection pipe 2. Rotate them to a proper angle and install them to their respective position. Seal the apertures with welding rod. First weld connection pipe 1 (liquid pipe) and then weld connection pipe 2 (gas pipe). During welding, it's necessary to use wet gauze to wrap up the filter near connection pipe 2 and the two cut-off valves. Make sure the flame won't burn the soundproof cotton or other components.

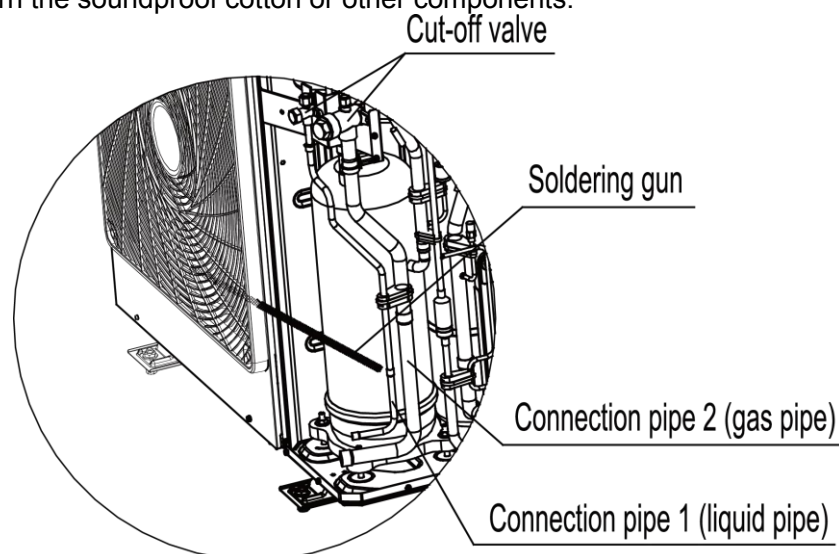

Fig. 17

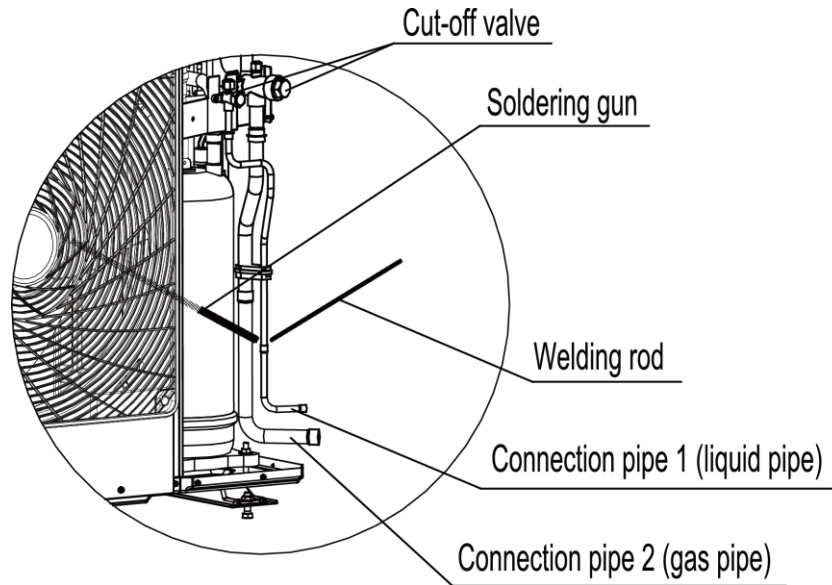

Fig.18

4.3.6 Installation of Y-type Branch

(1) Y-type Branch

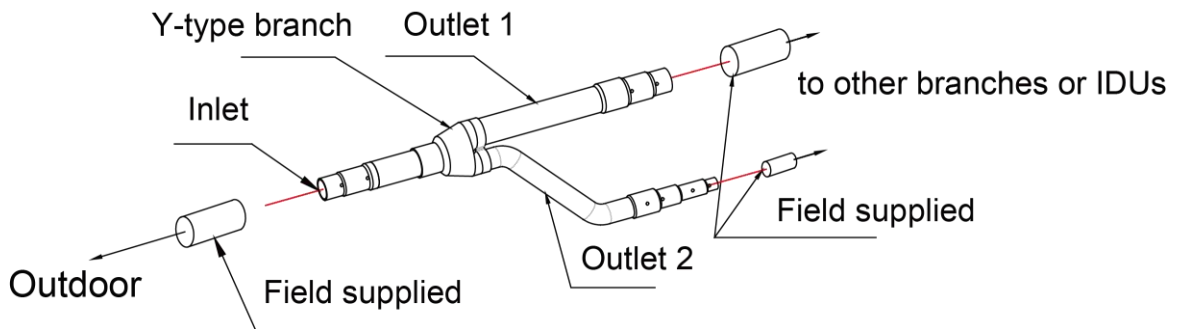

Fig.23

- (2) Y-type branch has several pipe sections with different dimension, which facilitates to match with various copper pipes. Use pipe cutter to cut in the middle of the pipe section that is of proper dimension and remove burrs as well. See Fig.17.
- (3) Y-type branch must be installed vertically or horizontally.

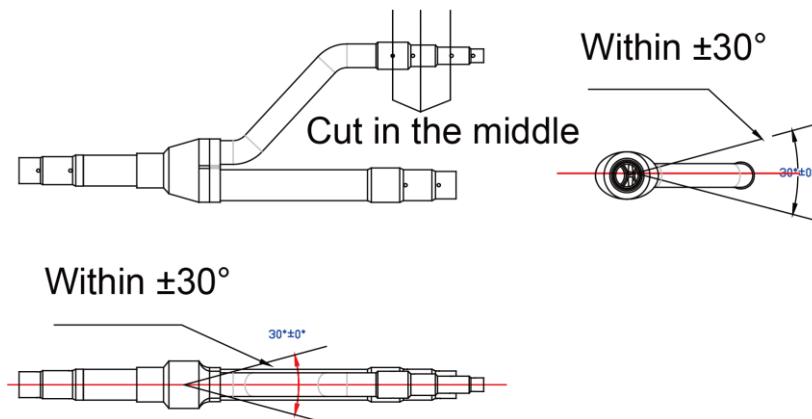

Fig.24

- (4) Branch shall be isolated by insulating material that can bear 120° or even higher temperature. The attached foam of branch cannot be taken as insulating material.

4.3.7 Thermal Insulation for Pipeline

- (1) For multi VRF system, every copper pipe should be labeled so as to avoid misconnection.
- (2) At the branch inlet, leave at least 500mm straight pipe section.
- (3) Thermal insulation for pipeline
 - 1) To avoid condensate or water leakage on the connection pipe, the gas pipe and liquid pipe must be wrapped with thermal insulating material and adhesive tape for insulation from the air.
 - 2) Thermal insulating material shall be able bear the pipe temperature. For heat pump unit, liquid pipe should bear 70°C or above and gas pipe should bear 120°C or above. For cooling only unit, both liquid pipe and gas pipe should bear 70°C or above.
 - 3) Example: Polyethylene foam (bear 120°C or above); foaming polyethylene (bear 100°C or above)
 - 4) Joints of indoor and outdoor unit should be wrapped with insulating material and leave no gap between pipe and wall. See Fig.18.

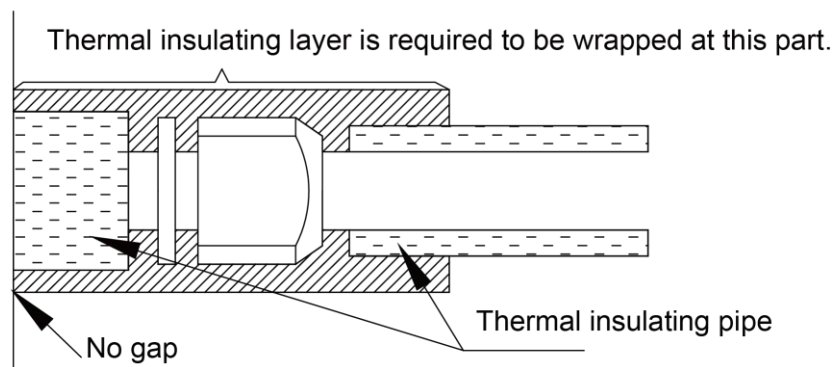

Fig.25

- 5) Thermal insulating material of branches should be the same as that of the pipeline. The attached foam of branches cannot be taken as insulating material.
- 6) When wrapping the tape, the later circle should cover half of the former one. Don't wrap the tape too tight, otherwise the insulation effect will be weakened.
- 7) After wrapping the pipe, apply sealing material to completely seal the hole on the wall.

4.3.8 Support and Protection of Pipeline

- (1) Support should be made for hanging connection pipe. Distance between each support cannot be over 1m.
- (2) Protection against accidental damage should be made for outdoor pipeline. When pipeline exceeds 1m, a pinch board should be added for protection.

4.4 Vacuum Pumping, Refrigerant Adding

4.4.1 Vacuum Pumping

- (1) Outdoor unit has been charged with refrigerant before delivery. Field-installed connection pipe needs to be charged with additional refrigerant.
- (2) Confirm whether outdoor liquid and gas valves are closed.
- (3) Use vacuum pump to withdraw the air inside indoor unit and connection pipe from the outdoor valve, as shown below.

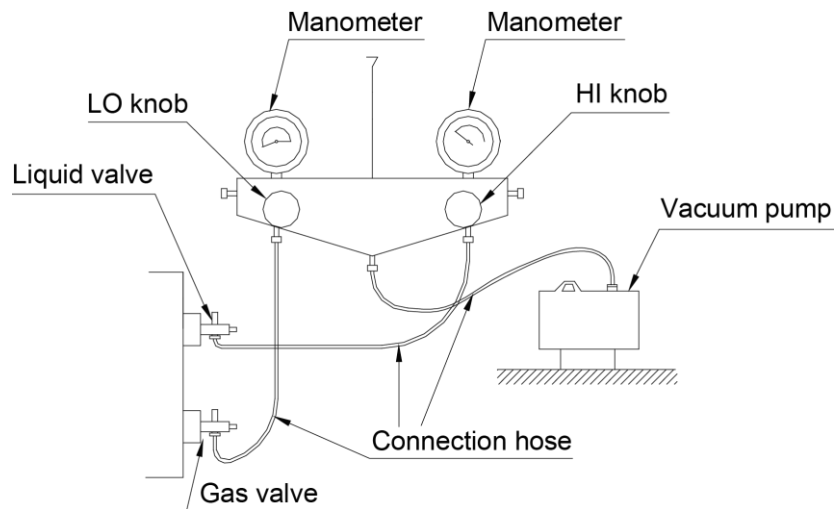

Fig. 26

4.4.2 Refrigerant Adding

- (1) Refrigerant quantity of outdoor unit before delivery:

Model	AOU-226VRDC3B	AOU-281VRDC3B	AOU-336VRDC3B
Refrigerant Qty (kg)	5.5	7.1	8.0



Note:

- ① The refrigerant amount charged before delivery doesn't include the amount that needs to be added to indoor units and the connection pipeline.
- ② Length of connection pipe is decided on site. Therefore the amount of additional refrigerant shall be decided on site according to the dimension and length of field-installed liquid pipe.
- ③ Record the amount of additional refrigerant for convenience of after-sales service.

- (2) Calculation of the amount of additional refrigerant

Calculation method of the quantity of additional refrigerant (based on liquid pipe)

Quantity of additional refrigerant = \sum length of liquid pipe X quantity of additional refrigerant per meter

Quantity of additional refrigerant per meter for liquid pipe (kg/m)					
Φ22.2	Φ19.05	Φ15.9	Φ12.7	Φ9.52	Φ6.35
0.35	0.25	0.17	0.11	0.054	0.022

First confirm that there is no leakage from the system. When compressor is not working, charge additional R410a with specific amount to the unit through the filling opening of the liquid

pipe valve of the outdoor unit. If required amount cannot be quickly filled due to pressure increase of the pipe, then set the unit in cooling startup and fill refrigerant from the low pressure check valve of the outdoor unit.

(3) Calculation example

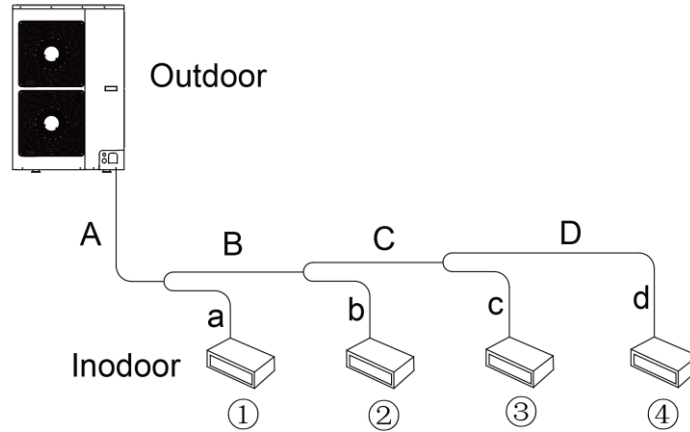

Fig. 27

IDU

No.	IDU ①	IDU ②	IDU ③	IDU ④
Model	Duct type ATMI-71VRDC1A□□	Duct type ATMI-56VRDC1A□□	Duct type ATMI-36VRDC1A□□	Duct type ATMI-28VRDC1A□□

Liquid pipe:

No.	A	B	C	D
Pipe size	Φ9.52	Φ9.52	Φ9.52	Φ6.35
Length	10m	5m	5m	5m
No.	a	b	c	d
Pipe size	Φ9.52	Φ6.35	Φ6.35	Φ6.35
Length	3m	3m	2m	1m

Total length of each liquid pipe

Φ9.52: $A+B+C+a=10+10+5+3=23\text{m}$

Φ6.35: $D+b+c+d=5+3+2+1=11\text{m}$

Therefore, the minimum quantity of additional refrigerant = $23 \times 0.054 + 11 \times 0.022 = 1.264\text{kg}$

4.5 Electric Wiring

4.5.1 Notices for Wiring

- (1) Install units according to national wiring codes.
- (2) Use air conditioner specialized power supply and make sure that it is consistent with system's rated voltage.
- (3) Do not pull the power cord with force.
- (4) All electrical installation must be performed by qualified technicians in accordance with local laws, regulations and this user manual.
- (5) Caliber of the power cord must be large enough. A damaged power cord or connection wire must be replaced by specialized electrical cords.
- (6) If the supply cord is damaged, it must be replaced by the manufacturer or its service agent or a similarly qualified person in order to avoid a hazard;
- (7) A circuit breaker having a contact separation of at least 3mm in all poles should be

fixed in fixed wiring

Connect the unit to specialized grounding device and make sure it is securely grounded. It's a must to install air switch and current circuit breaker that can cut off the power of the entire system. The circuit breaker should include magnetic trip function and thermal trip function so that system can be protected from short circuit and overload.

(8) Grounding Requirements

- 1) Air conditioner belongs to class I electrical appliance, so it must be securely grounded.
- 2) The yellow-green wire inside the unit is a ground wire. Do not cut it off or secure it with tapping screws, otherwise it will lead to electric shock.
- 3) Power supply must include secure grounding terminal. Do not connect the ground wire to the following:
 - ① Water pipe; ② Gas pipe; ③ Drain pipe;
 - ④ Other places that are deemed as not secure by professional technicians.

4.5.2 Wiring Diagram

(1) Connection of power cord and communication wire

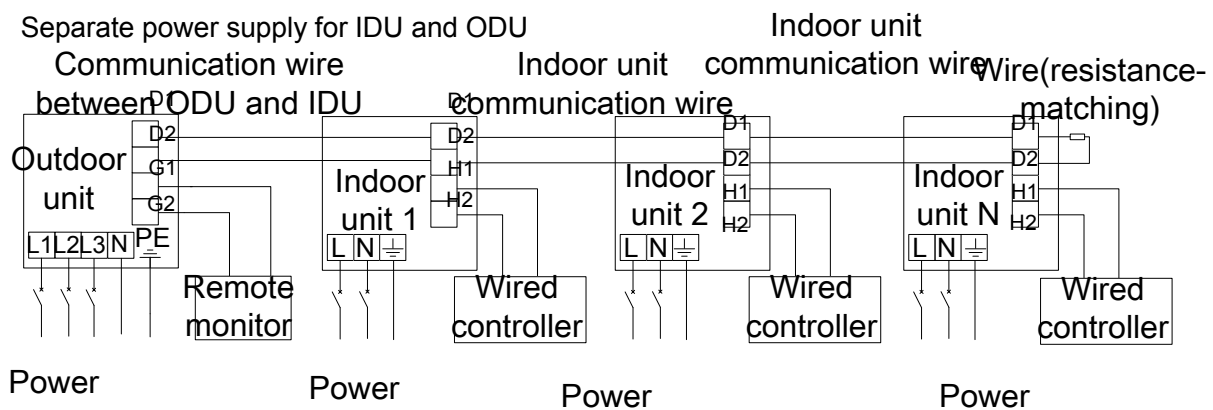

Fig.28 Connection of power cord and communication wire for IDU and ODU

(2) Selection of circuit breaker and power cord

Model	Power supply	Circuit breaker capacity (A)	(mm ²) Number of ground wire * Min sectional area (mm ²)	(mm ²) Number of power cord * Min sectional area (mm ²)
AOU-226VRDC3B	380-415V 3N~ 50/60HZ	20	1*2.5	4*2.5
AOU-281VRDC3B	380-415V 3N~ 50/60HZ	25	1*2.5	4*2.5
AOU-336VRDC3B	380-415V 3N~ 50/60HZ	25	1*2.5	4*2.5

Note:

- ① Selection of circuit breaker and power cord in the above table is based upon unit's maximum power (maximum current).
- ② Specification of power cord is based on the working condition where ambient temperature is 40°C and multi-core copper cable (working temperature is 90°C, e.g. power cable with YJV cross-linked copper,

insulated PE and PVC sheath) is lying on the surface of slot. If working condition changes, please adjust the specification according to national standard.

- ③ Specification of circuit breaker is based on the working condition where ambient temperature of circuit breaker is 40°C. If working condition changes, please adjust the specification according to national standard.
- ④ The communication wire between the indoor unit and the outdoor unit should wind with a magnetic ring (packed in the packing accessories). The communication wire should wind the magnetic ring for 4 circles, and the use the tieline to fix the magnetic ring at the meta sheet. Please refer to the diagrammatic sketch as below:



4.5.3 Engineering wiring of power supply and communication cable

- (1) Please refer Fig. 29 and 30 for engineering wiring. If there is the hole for cable tie in wiring route, please fix the wire with cable tie. Connect the power cord and communication cable to the corresponding terminal board and grounding screw according to the wiring diagram.
- (2) Please be noted that engineering wiring cannot touch the pipe and appliance.
- (3) This figure is only applicable for engineering wiring reference of power supply and communication cable. If there are differences between the figure structure and actual unit, please refer to the actual unit.
- (4) For engineering wiring, please refer to the wiring diagram provided with the unit.

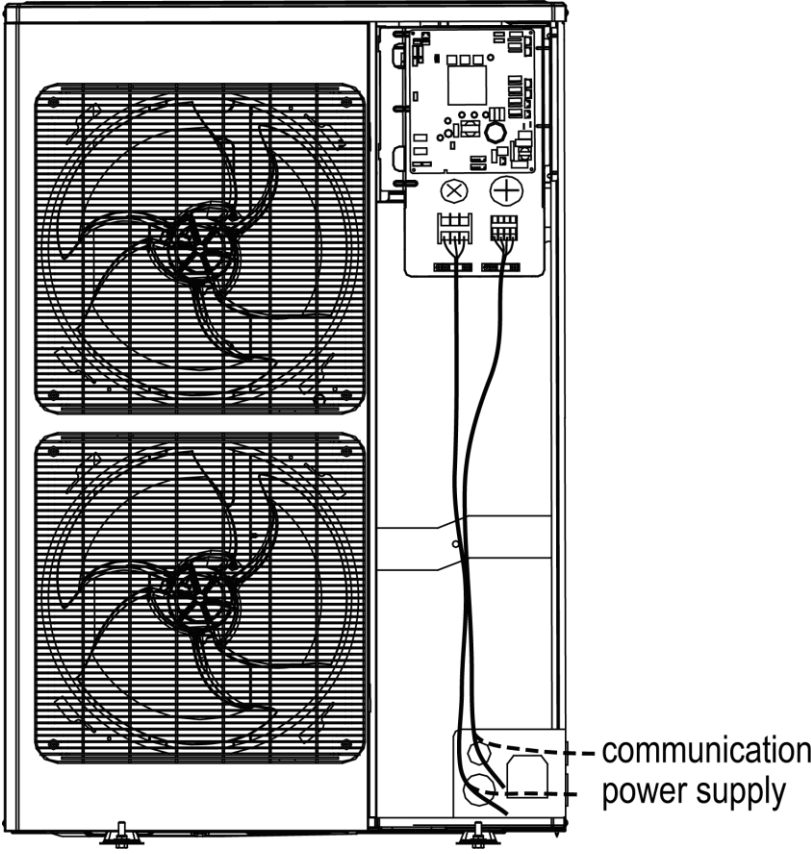

Fig. 29 Engineering Wiring View of AOU-226VRDC3B

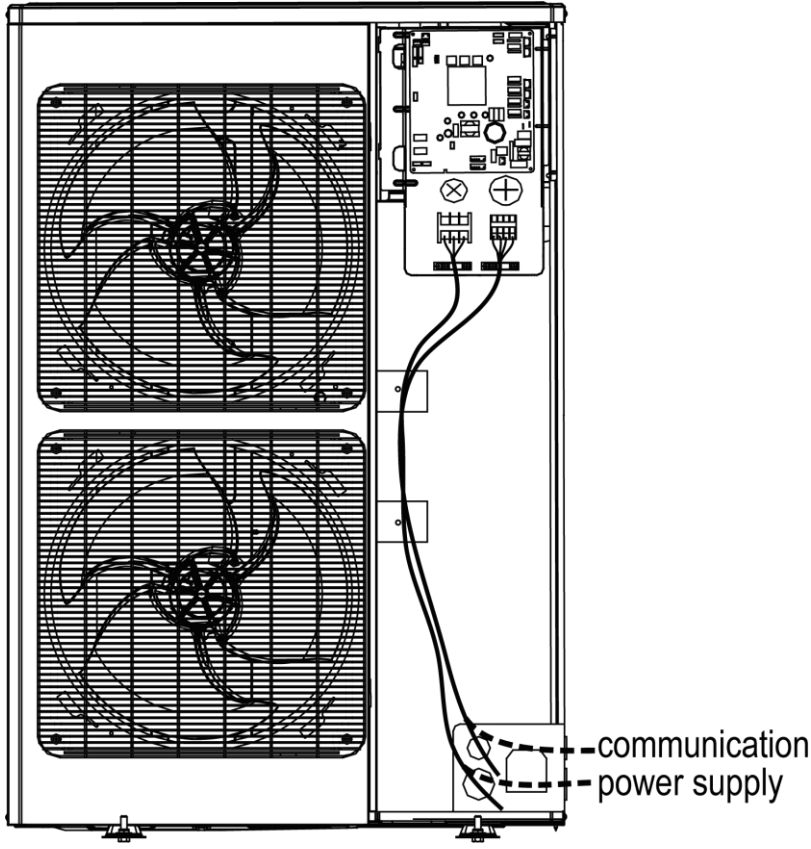

Fig. 30 Engineering Wiring View of AOU-281VRDC3B,AOU-336VRDC3B

5 Check Items after Installation and Test Operation

5.1 Check Items after Installation

Check items	Possible conditions due to improper installation	Check
Each part of the unit is installed securely?	Unit may drop, shake or emit noise.	
Gas leakage test is taken or not?	Insufficient cooling (heating) capacity	
Unit gets proper thermal insulation or not?	There may be condensation and dripping.	
Drainage is smooth or not?	There may be condensation and dripping.	
Is the voltage in accordance with the rated voltage specified on the nameplate?	Unit may have malfunction or components may get damaged.	
is the electric wiring and pipe connection installed correctly?	Unit may have malfunction or components may get damaged.	
Unit is securely grounded or not?	Electrical leakage	
Power cord meets the required specification?	Unit may have malfunction or components may get damaged.	
Is the air inlet/outlet blocked?	Insufficient cooling (heating) capacity	
Length of refrigerant pipe and the charging amount of refrigerant are recorded or not?	The refrigerant charging amount is not accurate.	
Binding pieces on compressor feet are removed or not?	Compressor may get damaged.	

5.2 Test operation and debugging

Notice:

- ① After finishing the first installation or replacing the main board of outdoor unit, it is necessary to perform test operation and debugging. Otherwise, unit won't be able to work.
- ② Test operation and debugging must be performed by professional technicians or under the guidance of professional technicians.

5.2.1 Prepare the test operation and debugging

- (1) Do not connect power until all installation work is finished.
- (2) All control circuits and wires are correctly and securely connected.
- (3) Check whether the fixing loops for compressor foots are removed.
- (4) All small pieces, especially metal chips, thread ends and forceps holder, must be removed from the unit.
- (5) Check whether unit's appearance and pipeline system has been damaged during transportation.
- (6) Calculate the quantity of refrigerant that needs to be added according to the pipe length. Pre-charge the refrigerant. In case that the required charging quantity is not reached while refrigerant can't be added, record the quantity of refrigerant that still needs to add and complement the quantity during test operation. For details of adding refrigerant during test operation, see below.
- (7) After refrigerant is added, make sure valves of outdoor unit are completely open.
- (8) For the convenience of troubleshooting during debugging, unit shall be connected to a PC with applicable debugging software. Make sure unit's real-time data can be checked through this computer. The installation and connection of debugging software can be found in the Service Manual.
- (9) Before test operation, make sure unit is power on and compressor has been preheated for more than 8 hours. Touch the unit to check whether it's normally preheated. If yes, start test operation. Otherwise, compressor might be damaged.
- (10) If the LED digital tube on main board displays __ __ __ __, then input the startup password. For operation details, please see the instructions for the function of startup password.

5.2.2 Test Operation and Debugging

Description of test operation procedures and main board display of ODU

Description of each stage of debugging progress							
—	Debugging code		Progress code		Status code		Code meaning and operation method
Progress	LED1		LED2		LED3		
	Code	Display status	Code	Display status	Code	Display status	
01_ Set master unit	db	On	01	On	AO	On	System is not debugged.
	db	On	01	On	OC	On	Hold main board's SW7 button for 5s to start debugging. Main board will display as said in the left. 2s later, next step starts.
02_ Allocate addresses	db	On	02	On	Ad	Blink	System is allocating addresses. 10s later, display as below:
	db	On	02	On	L7	Blink	No master indoor unit. Display will be on for 1min, during which master IDU can be set manually. If not, system will set the unit with minimum IP address as the master IDU.
	db	On	02	On	OC	On	Allocation is finished. 2s later, next step starts.
03_ Confirm the quantity of ODU	db	On	03	On	01	Blink	System is confirming. 1s later, next step starts.
	db	On	03	On	OC	On	System finishes confirmation. 2s later, next step starts.
04_ Confirm the quantity of IDU	db	On	04	On	01~8 0	Blink	LED3 displays the quantity of indoor unit. Confirm the number manually. If the number is not consistent the display one, cut off power of IDU and ODU and check whether communication wire of IDU is correctly connected. After the check, connect power and start debugging from progress 01. If the number is then correct, press main board's SW7 button to confirm. Then the display is as below:
	db	On	04	On	OC	On	System has confirmed the quantity. 2s later, next step starts.
05_ Detect ODU's internal communication and capacity ratio	db	On	05	On	C2	On	Communication between master ODU and driver has error. Check the communication connection of ODU's main board and drive board. When the error is eliminated, start next step. If power is off during troubleshooting, then restart debugging from progress 01 after power is on.
	db	On	05	On	OC	On	Communication of master ODU and driver is normal. Unit will display as in the left for 2s and detect the capacity ratio of IDU and ODU. If the ratio is within range, than next step will start 2s later. If the ratio is out of range, unit will display as below:
	db	On	05	On	CH	On	Rated capacity ratio of IDU is too high. Change the combination way of IDU and ODU to make the ratio within range. And restart debugging from progress 01.
	db	On	05	On	CL	On	Rated capacity ratio of IDU is too low. Change the combination way of IDU and ODU to make the ratio within range. And restart debugging from progress 01.

06_ Detect outdoor components	db	On	06	On	error code	On	Outdoor component's error. LED3 will display the related error code. After errors are eliminated , system will start next step automatically. If power is off during troubleshooting, then restart debugging from progress 01 after power is on.
	db	On	06	On	OC	On	System detects no error on outdoor component. 10s later, next step starts.
07_ Detect indoor components	db	On	07	On	XXXX / Error code	On	System detects error on indoor components. XXXX means the project code of IDU with error. 3s later, related error code will be showed. For instance, if no.1 IDU has d6 and d7 errors, then the LED3 digital tube will show circularly 00,01,d5,d6,07,92,d6,d7 every 2s. After errors are eliminated , system will start next step automatically. If power is off during troubleshooting, then restart debugging from progress 01 after power is on.
	db	On	07	On	OC	On	No error on components of IDU. 2s later, next step starts.
08_ Confirm preheated compressor	db	On	08	On	UO	On	Preheat time for compressor is less than 8 hours. Display will be as in the left until the preheat time reaches 8 hours. Press main board's SW7 button to confirm manually that the preheat time has reached 8 hours. Then start next step. (Note: Compressor may get damaged if it is started without 8 hours of preheat time)
	db	On	08	On	OC	On	Compressor has been preheated for 8 hours. 2s later, next step starts.
09_ Refrigerant judgments before startup	db	On	09	On	U4	On	System is lack of refrigerant and display will be as in the left. Please cut off power of IDU and ODU and check if there is leakage on pipeline. Solve the leakage problem and complement refrigerant into the unit. Then connect power and restart debugging from progress 01. (Note: Before re-charging refrigerant, unit must be power off in case system starts progress 10 automatically.)
	db	On	09	On	OC	On	Refrigerant is normal and unit will display as in the left for 2s. Then next step starts.
10_ Status judgments of outdoor valves before startup	db	On	10	On	ON	On	Valves of ODU are being inspected. Compressor will start operation for 2min or so and then stop. The opening and closing status of outdoor valves are as below:
	db	On	10	On	U6	On	Outdoor valves are not fully turned on. Press main board's SW6 button and display shows "db 09 OC". Then check if the gas and liquid valves of ODU are completely open. After confirmation, press the SW6 button again . Then compressor will start running for about 2min to inspect the status of valves.
	db	On	10	On	OC	On	Valves status is normal. Unit will display as in the left for 2s and then start next step.
12_ Confirm debugging startup	db	On	12	On	AP	Blink	Ready for units to start debugging. Press main board's SW7 button to confirm startup of debugging. 2s later, main board will display as below:

	db	On	12	On	AE	On	Startup is confirmed. After displaying for 2s, system will choose "15_Cooling debugging" or "16_Heating debugging" according to ambient temperature. If the project requests to add refrigerant but it is not complemented before debugging, then refrigerant can be added in this process through the L-VALVE.
15_ Cooling debugging	db	On	15	On	AC	On	Debugging for cooling mode. If no malfunction occurs for 20min when compressor is running, then system will start progress 17; If malfunction occurs, unit will display as below:
	db	On	15	On	Error code	On	Malfunction occurs when debugging for cooling mode. After all malfunctions are eliminated , system will start next step.
16_ Heating debugging	db	On	16	On	AH	On	Debugging for heating mode. If no malfunction occurs for 20min when compressor is running, then system will start progress 17; If malfunction occurs, unit will display as below:
	db	On	16	On	Error code	On	Malfunction occurs when debugging for heating mode. After all malfunctions are eliminated , system will start next step.
17_ Debugging finished	00	On	AC/A H	On	OFF	On	The entire unit has finished debugging and under standby-by condition.

5.2.3 Appendix: Reference of normal operation parameters

No.	Debug item		Parameter name	Unit	Reference
1	System parameters	ODU parameters	Outdoor temperature	°C	—
2			Compressor discharge temperature	°C	<ul style="list-style-type: none"> When compressor starts, discharge temp in cool mode is within 70~105°C and at least 10°C higher than the high pressure saturation temp; As for temp in heat mode, it is within 65~90°C and at least 10°C higher than the high pressure saturation temp.
3			Defrosting temperature	°C	<ul style="list-style-type: none"> In cool mode, defrosting temp is 4~10°C lower than system's high pressure value; In heat mode, defrosting temp is about 2°C different from system's low pressure value.
4			System high pressure	°C	<ul style="list-style-type: none"> In cool mode, the normal high pressure value is within 20°C~55°C. According to the change of ambient temp and system's operating capacity, the high pressure value will be 10°C~30°C higher than ambient temp. The higher ambient temp is, the smaller temp difference is. If ambient temp is 25~35°C in cool mode, system's high pressure value will be within 44~53°C. In heat mode, if ambient temp is above -5°C, system's high pressure value is within 40~52°C. If ambient temp is low and many IDUs are turned on, the high pressure will be lower.
5			System low pressure	°C	<ul style="list-style-type: none"> When ambient temp in cool mode is 25~35°C, the low pressure value is 0~8°C. When ambient temp in heat mode is above -5°C, the low pressure value is -15~8°C.
6			Opening angle of thermal EXV	PLS	<ul style="list-style-type: none"> In cool mode, the thermal electronic expansion valve remains 480PLS. In heat mode, the adjustable opening angle of EXV is 60~480PLS.

7			Compressor working current		AOU-226VRDC3B	When compressor works normally, the current is no more than 18.0A.
					AOU-281VRDC3B	When compressor works normally, the current is no more than 23.0A.
					AOU-336VRDC3B	When compressor works normally, the current is no more than 25.0A.
8			Compressor's IPM temp	°C	When ambient temperature is below 35°C, IPM temperature is lower than 70°C. Maximum temperature is 80°C.	
9		IDU parameters	IDU ambient temp	°C	—	
10			Indoor heat exchanger's inlet temp	°C	<ul style="list-style-type: none"> ●According to ambient temp, for a same IDU in cool mode, the inlet temp will be 1°C~7°C lower than the outlet temp, and 4~9°C higher than the low pressure value. ●For a same IDU in heat mode, the inlet temp will be 10°C~20°C lower than the outlet temp. 	
11			Indoor heat exchanger's inlet temp	°C		
12			Opening angle of indoor EXV	PLS	<ul style="list-style-type: none"> ●In cool mode, the opening angle of indoor EXV varies within 40~480PLS. ●In heat mode, the opening angle of indoor EXV varies within 70~480PLS. 	
13	Communication parameters		Communication data	—	Number of IDUs detected by software is the same with the actual number. No communication error.	
14	Drainage system		—	—	Indoor unit can drain water out completely and smoothly. Condensate pipe has no backward slope of water; Water of outdoor unit can be drained completely through drainage pipe. No water drop from unit base.	
15	Others		—	—	Compressor and indoor/outdoor fan motor do not have strange noise. Unit can operate normally.	

6 Common Malfunctions and Troubleshooting



Warning:

- ① If there is abnormal condition (e.g. unpleasant smell), turn unit off and disconnect power immediately.
Then contact ALPICAIR authorized service center. If unit continues operation despite the abnormal condition, it may get damaged and lead to electric shock or fire hazard.
 - ② Do not repair the air conditioner by yourself. Improper maintenance may lead electric shock or fire hazard.
Please contact ALPICAIR authorized service center for maintenance.
- (1) Please check the items below before calling for maintenance.

Problems	Causes	What to do
Unit doesn't work.	Fuse or circuit breaker is cut off.	Replace fuse or reset the circuit breaker.
	Power failure	Restart unit when power is restored.
	Power is not connected.	Connect the power.
	Remote controller's power is not enough	Replace new battery.
	Remote controller is out of the control range.	Control range is within 8m.
Unit runs but stops immediately.	Air inlet or air outlet of indoor and outdoor units is blocked.	Clear obstructions.
Abnormal cooling or heating	Air inlet or air outlet of indoor and outdoor units is blocked.	Clear obstructions.
	Improper temp setting	Adjust setting at remote controller or wired controller
	Fan speed is set too low.	Adjust setting at remote controller or wired controller
	Wind direction is not correct.	Adjust setting at remote controller or wired controller
	Door or window is open.	Close the door or window.
	Direct sunshine	Draw curtain or louver.
	Too many people in the room.	
	Too many heat resources in the room.	Reduce heat resources.
Filter is blocked and dirty.	Clean the filter	

Note:

If problem cannot be solved after checking the above items, please contact ALPICAIR service center and describe the cases and models.

(2) Following circumstances are not malfunctions.

Malfunction		Reason
Unit doesn't run.	Unit starts up immediately after it is turned off.	Overload protection switch makes it run after a 3-min delay.
	Power is just turned on.	Standby operation lasts for about 1min.
Mist comes from the unit.	Under cooling	Indoor air with high humidity is cooled rapidly.
Noise is emitted.	Slight cracking sound is heard when unit is just turned on.	It is the noise when electronic expansion valve is initialized.
	There is consecutive sound when cooling.	It is the sound for gas refrigerant flowing in the unit.
	There is sound when unit starts or stops.	It is the sound when gas refrigerant stops flowing.
	There is slight and consecutive sound when unit is running or after running.	This is the sound of drainage operation.
	Cracking sound is heard when unit is running or after running.	This is the sound caused by the expansion of panel and other parts of the unit due to temperature change.
Unit blows out dust.	Unit starts up after not operating for a long time.	Dust in indoor unit is blown out.
Unit emits odor.	Under operation	Unit absorbs the room odor and then blows it out.

7 Error Indication

Inquiry method of error indication: combine division symbol and content symbol to check the corresponding error.

For example, division symbol L and content symbol 4 together means over-current protection.

	Error Code	Content	Error Code	Content
Indoor	L0	Malfunction of IDU (uniform)	L1	Protection of indoor fan
	L2	Auxiliary heating protection	L3	Water-full protection
	L4	Over-current protection	L5	Freeze prevention protection
	L6	Mode shock	L7	No main IDU
	L8	Power supply is insufficient	L9	1-to-more: number of IDU is inconsistent
	LA	1-to-more: IDU series is inconsistent	LH	Alarm due to bad air quality (Fresh air unit)
	LC	Models for IDU and ODU are not matched	EC	Drop protection of discharge temperature sensor of compressor 1
	d1	Indoor PCB is poor	d3	Malfunction of ambient temperature sensor
	d4	Malfunction of entry-tube temperature sensor	d5	Malfunction of middle temperature sensor
	d6	Malfunction of exit-tube temperature sensor	d7	Malfunction of humidity sensor
	d9	Malfunction of jumper cap	dA	Web address of IDU is abnormal
	dH	PCB of wired controller is abnormal	dC	Abnormal setting for capacity button
	dL	Malfunction of air-outlet temperature sensor(Fresh air unit)	dE	Malfunction of indoor CO ₂ sensor (fresh air unit)
	FP	Malfunction of DC motor	J7	Gas-mixing protection of 4-way valve
	J8	High pressure ratio protection of system	J9	Low pressure ratio protection of system
JA	Protection due to abnormal pressure	JL	High-pressure protection	

	b6	Malfunction of inlet temp sensor of gas-liquid separator	b7	Malfunction of outlet temp sensor of gas-liquid separator
	b9	Malfunction of heat exchanger temperature sensor	bH	Clock of system is abnormal
	P6	Drive IPM module protection of compressor	P7	Malfunction of drive temperature sensor of compressor
	P8	Drive IPM high temperature protection of compressor	P9	Desynchronizing protection of inverter compressor
	PH	High-voltage protection of compressor's drive DC bus bar	PC	Drive current detection circuit malfunction of compressor
	PL	Low-voltage protection of compressor's drive DC bus bar	PE	Phase-lacking of inverter compressor
	PF	Drive charging circuit malfunction of compressor	PJ	Failure startup of inverter compressor
	PP	AC current protection of inverter compressor	H6	Drive IPM module protection of fan
	H7	Malfunction of drive temperature sensor of fan	H8	Drive IPM high temperature protection of fan
	H9	Desynchronizing protection of inverter fan	HH	High-voltage protection of fan's drive DC bus bar
	HC	Drive current detection circuit malfunction of fan	HL	Low-voltage protection of fan's drive DC bus bar
	HE	Phase-lacking of inverter fan	HF	Drive charging circuit malfunction of fan
	HJ	Failure startup of inverter fan	HP	AC current protection of inverter fan
Outdoor	E0	Malfunction of ODU (uniform)	E1	High-pressure protection
	E2	Discharge low-temperature protection	E3	Low-pressure protection
	E4	High discharge temperature protection of compressor	E5	High discharge temperature protection of compressor 1
	F0	Main board of ODU is poor	F1	Malfunction of high-pressure sensor
	F3	Malfunction of low-pressure sensor	F5	Malfunction of discharge temperature sensor of compressor 1
	J1	Over-current protection of compressor 1	b1	Malfunction of outdoor ambient temperature sensor
	b2	Malfunction of defrosting temperature sensor 1	b4	Malfunction of liquid temperature sensor of sub-cooler
	b5	Malfunction of gas temperature sensor of sub-cooler	P0	malfunction of driving board of compressor (uniform)
	P1	Driving board of compressor operates abnormally (uniform)	P2	Voltage protection of driving board power of compressor (uniform)
	P3	Reset protection of driving module of compressor	P4	Drive PFC protection of compressor
	P5	Over-current protection of inverter compressor	H0	Malfunction of driving board of fan (uniform)
	H1	Driving board of fan operates abnormally (uniform)	H2	Voltage protection of driving board power of fan (uniform)
	H3	Reset protection of driving module of fan	H4	Drive PFC protection of fan
	H5	Over-current protection of inverter fan		
	Debugging	U0	Preheat time of compressor is insufficient	U2
U4		Refrigerant-lacking protection	U5	Wrong address for driving board of compressor
U6		Alarm because valve is abnormal	U8	Short-circuit malfunction of IDU
U9		Malfunction of pipe-line for ODU	UC	Setting of main IDU is successful

	UL	Wrong button-dial	UE	Charging of refrigerant is invalid
	C0	Communication malfunction between IDU, ODU and IDU's wired controller	C2	Communication malfunction between main control and inverter compressor driver
	C3	Communication malfunction between main control and inverter fan driver	C4	Malfunction of lack of IDU
	C5	Alarm because project code of IDU is inconsistent	C8	Emergency status of compressor
	C9	Emergency status of fan	CH	Rated capacity is too high
	CC	Malfunction of lack of main control unit	CL	Rated capacity is too low
	CF	Malfunction of multiple main control units	CJ	Malfunction of multiple main wired controllers
	CP	Malfunction of multiple main wired controllers	CU	Communication malfunction between IDU and the receiving lamp plate
	Cb	Overflow distribution of IP address		
Status	A0	Unit waiting for debugging	A1	Inquiry of compressor operation parameters
	A2	Refrigerant recovery operation of after-sales	A3	Defrosting
	A4	Oil-return	A5	Online test
	A6	Heat pump function setting	A7	Quiet mode setting
	A8	Vacuum pump mode	A9	IPLV test
	AA	EU AA level EER test mode	AH	Heating
	AC	Cooling	AL	Charging refrigerant automatically
	AE	Charging refrigerant manually	AF	Fan
	AJ	Alarm for cleaning filter	AP	Debugging confirmation for startup of unit
	AU	Long-distance emergency stop	Ab	Emergency stop of operation
	Ad	Limit operation	n0	SE operation setting of system
	n1	Setting of defrosting cycle K1	n2	Setting of upper limit of IDU/ODU capacity distribution ratio
	n4	Limit setting for max. capacity/output capacity	n6	Inquiry of project code of IDU
	n7	Inquiry of malfunction	n8	Inquiry of parameters
	nA	Heat pump unit	nH	Heating only unit
	nC	Cooling only unit	nE	Negative sign code
nF	Fan model			

8 Function Setting of Outdoor Unit

When debugging is finished, press SW3 on the master unit and unit will be ready for function setting. Default display of outdoor unit's main board is as below:

LED1		LED2		LED3	
Function code	Display	Current progress	Display	Current status	Display
A7	Blink	00	Blink	00	Blink

Then press SW1 button(▲) and SW2 button(▼) on the master unit to switch function codes of LED1 to select relevant functions.

Function setting includes: outdoor silent mode setting (A7), heating and cooling function setting (A6), compulsory defrosting (n3)

After selecting relevant functions, press SW7 to confirm and start setting this function. Main board of outdoor unit will display as below:

LED1		LED2		LED3	
Function code	Display	Current progress	Display	Current status	Display
A7	On	00	Blink	oC	Blink
A6	On	CH	Blink	CH	Blink
n3	On	35	Blink	oC	Blink

8.1 ODU Quiet Function

This function is suitable for projects that have strict requirements for noise. It includes two modes: smart night silent mode, compulsory silent mode.

When unit enters function setting, main board of outdoor unit will display as below:

LED1		LED2		LED3	
Function code	Display	Current progress	Display	Current status	Display
A7	On	00	Blink	oC	Blink

Press SW1 button (▲) and SW2 button (▼) to select the following silent modes.

LED1		LED2		LED3	
Function code	Silent mode	Display	Current status	Display	
A7	00~12	Blink	oC	Blink	

When applicable mode is selected, press SW7 to confirm. Main board of outdoor unit will display as below:

LED1	LED2		LED3	
Function code	Silent mode	Display	Current status	Display
A7	00~12	On	oC	On

Notice: code 00 of LED2 refers to normal mode. Codes 01~09 refer to smart night silent mode. Codes 10~12 refer to compulsory silent mode. When setting is finished, master unit will memorize it so that it can't be cancelled even when power is on or off.

Then press SW6 on the master unit to return to the previous step. (If this button is pressed when function is being set, system will return to the previous step. If SW6 is pressed when setting is finished, system will resume displaying the current operation status.)

If then no motion is taken to the master unit for 5min, unit will exit and resume displaying the current status.

8.2 Cool & Heat Function

This function can set operation modes and prevent mode collision that is caused by setting different modes for different indoor units. It is especially suitable for hotels and other small business areas. There are 3 levels for this setting:

Level A—Mode Lock Control

Upon entering this function setting, main board of outdoor unit will display as below:

LED1	LED2		LED3	
Function code	Current progress	Display	Current status	Display
A6	nC	Blink	nC	Blink

Press SW1 button (▲) and SW2 button (▼) to select the following functions:

LED1		LED2		LED3	
Function code	Display	Current progress/mode	Display	Current status	Display
A6	On	nC	Blink	nC	Blink
A6	On	nH	Blink	nH	Blink
A6	On	nA	Blink	nA	Blink
A6	On	nF	Blink	nF	Blink

When applicable mode is selected, press SW7 to confirm. The related display is as below:

LED1		LED2		LED3	
Function code	Display	Current progress/mode	Display	Current status	Display
A6	On	nC	On	nC	On
A6	On	nH	On	nH	On
A6	On	nA	On	nA	On
A6	On	nF	On	nF	On

This setting will be memorized by master unit and can't be cancelled even when power is on or off.

Then press SW6 on the master unit to return to the previous step.

If then no motion is taken to the master unit for 5min, unit will exit and resume displaying the current status.

(If this button is pressed when function is being set, system will return to the previous step. If SW6 is pressed when setting is finished, system will resume displaying the current operation status.)

Default setting is "nA" cooling and heating type.

Level B—IDU Mode Auto Control

When Level A is disabled or outdoor unit is set to be cooling and heating type, the operation mode within one system depends on the master-slave setting of indoor units.

8.3 Forced Defrosting

This function can only be set when outdoor compressor is running.

Upon entering this function, main board of outdoor unit will display as below:

LED1		LED2		LED3	
Function code	Display	Current progress/mode	Display	Current status	Display
n3	On	00	Blink	00	Blink

Press SW7 to confirm. When system enters this function, main board of outdoor unit will display as below:

LED1		LED2		LED3	
Function code	Display	Current progress/mode	Display	Current status	Display
n3	On	00	On	00	On

Then unit will be in compulsory defrosting mode. Once unit is under compulsory defrosting, this mode can only be stopped when requirements for exit are met.

8.4 Restore Factory Defaults

i.If you want to restore factory defaults, hold SW8 button on the main board of ODU for more than 10s, then all LEDs will blink for 3s. Main board will cancel all setting, including the IP addresses and project codes of IDU and ODU. The mark for finished debugging is “0”.

ii.If you want to restore factory defaults and don't need project debugging, then hold SW3 and SW8 on the main board of ODU for more than 10s, then all LEDs will blink for 5s. All settings are cleared out, including the IP addresses and project codes of IDU and ODU. The mark for finished debugging remains the same.

iii.When you only want to restore the default functions, hold SW5 and SW8 button for more than 10s, then all LED will blink for 7s. All function settings are cleared out, but IDU and ODU's project codes and the mark for finished debugging remain the same.

8.5 Static Pressure Function

If ODU's installation area is not convenient for releasing air and users do not have strict requirements for ODU noise, this function can be set to satisfy the heat exchange of ODU.

Before power on, set codes of SA6 of main board. The relevant static pressure is:

Code setting SA6		Static pressure (Pa)
DIP1	DIP2	
0	0	0
1	0	20

Note: code of number side is “1”; default code of SA6 is “00”.

9 Maintenance and Care

Regular check, maintenance and care can extend unit's service life. Please have specialized person in charge of the management of air conditioners.

9.1 Outdoor Heat Exchanger

Outdoor heat exchanger shall be cleaned regularly, which is at least once every two months. You can use a dust catcher with nylon brush to clean away the dust on the heat exchanger. If compressed air source is available, it also can be used to clean the heat exchanger. Do not clean it with water.

9.2 Drain Pipe

Please check regularly whether drain pipe is blocked or not. Make sure condensate can be drained out smoothly.

9.3 Notice before Seasonal Use

- (1) Check whether air inlets and air outlets of indoor and outdoor units are blocked;
- (2) Check whether ground connection is reliable or not;
- (3) Check whether batteries in the remote controller are replaced or not;
- (4) Check whether air filter is properly installed;
- (5) If unit starts up after not operating for a long time, it should be power on 8 hours before operation starts so as to preheat the outdoor compressor;
- (6) Check whether outdoor unit is securely installed. If there is any problem, please contact ALPICAIR authorized service center.

9.4 Maintenance after Seasonal Use

- (1) Disconnect power of the entire system;
- (2) Clean the air filter and outer case of indoor and outdoor units;
- (3) Clean away the dust and obstacles on indoor and outdoor units;
- (4) If outdoor unit has rust, please apply some paint to it so as to prevent the rust from growing.

9.5 Parts Replacement

Parts and components can be obtained from nearby ALPICAIR office or ALPICAIR distributor.



Note:

When you are conducting air tightness test and leakage test, do not mix oxygen, C₂H₂ or other dangerous gas into the refrigerant circuit. Otherwise, it may lead to danger. Use nitrogen or refrigerant to conduct the tests.

10 After-sales Service

If there's quality defect or other problems in the product, please contact ALPICAIR local after-sales service department for help.

Warranty must be based on the following conditions:

- (1) Product's initial startup must be performed by professional technicians from ALPICAIR service center or persons assigned by ALPICAIR.
- (2) Only ALPICAIR spare parts are used,
- (3) All instructions of unit operation and maintenance in this manual must be strictly followed according to set period and set frequency.
- (4) Any breach of the above conditions will disable the warranty.



66129927073